

# Reliable®

## Model B1 Accelerator With Integral Accelo-Check

Bulletin 322 Rev.N

## Instructions for Installation, Operation, Care and Maintenance

Listed by Underwriters Laboratories, Inc. Approved by Factory Mutual Corp., and other fire insurance and governmental agencies in the United States and foreign countries.

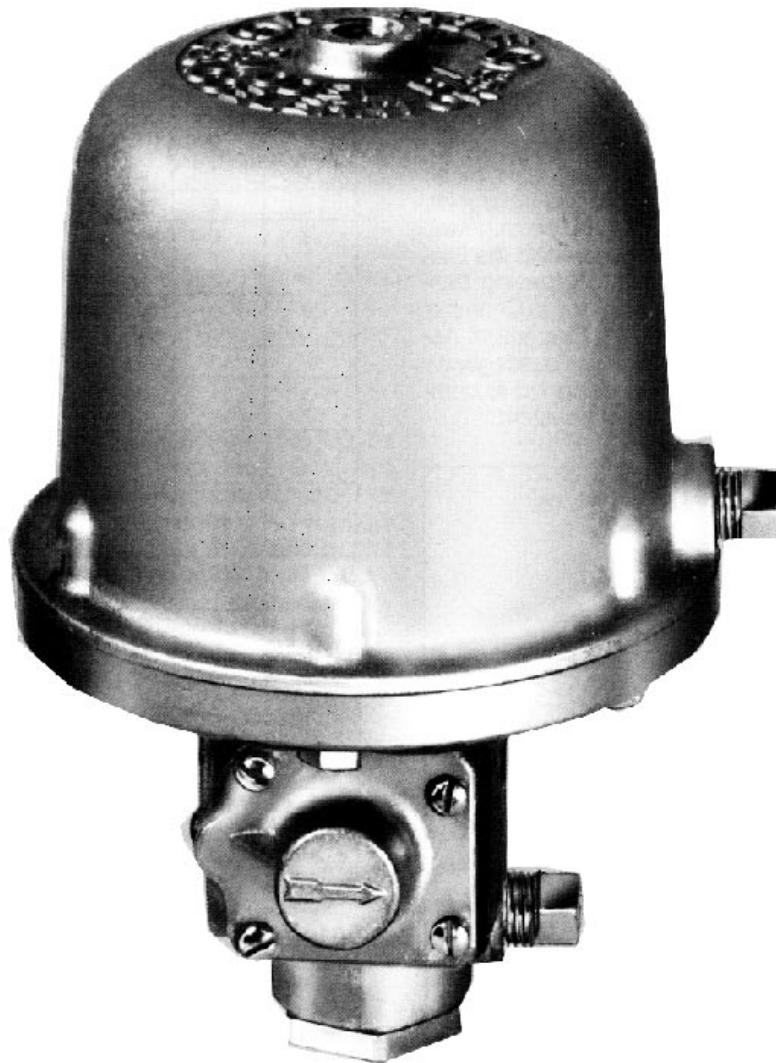

Patent No. 3,785,440

**The Reliable Automatic Sprinkler Co., Inc.,** 525 North MacQuesten Parkway, Mount Vernon, New York 10552

## General

The Reliable Model B1 Accelerator with its integral Accelo-Check (anti-flooding device) is used to speed the operation of dry pipe valves in dry type automatic sprinkler systems. Dry systems use air under pressure instead of water because of freezing temperatures which may exist. A Model B1 Accelerator may also be used in some Preaction Systems of the Double Interlock type (ref. Bulletin 710).

## Accelerator Operation

The Model B1 Accelerator is a normally closed valve with  $\frac{1}{2}$ " NPT ports, and it is sensitive to a rate of air pressure change. This device retains normal dry system air pressure in the top chamber, Figure 2, even though the system air pressure may be dropping, such as when one or more sprinklers open. The resulting differential force which is created across the Diaphragm Assembly (5-8) forces the Poppet (15) open, allowing system air pressure to pass to the intermediate chamber of the dry pipe valve and causing it to open. Simultaneously, pressurized air passes through the accelerator and closes the integral Accelo-Check (11,20-24) by pressurizing cavity H and preventing water and waterborne debris from entering the internal restriction area in passageway G. This increases the reliability of the device and reduces the maintenance which would otherwise be required to clean the accelerator after each operation.

Figure 2 depicts the accelerator in the closed position while being pressurized. The accelerator is filled by air from the dry pipe system entering the accelerator inlet, passing through the Filter Assembly (18) and passageway E to the Middle Chamber. The air pressure lifts the Diaphragm Assembly off the Push Rod (10) opening passageway G. The air then completely fills the Top Chamber to the system pressure. When filled, the Diaphragm Assembly rests on the push rod end and closes passageway G, except for minor leakage which is designed to compensate for air pressure fluctuations in the system.

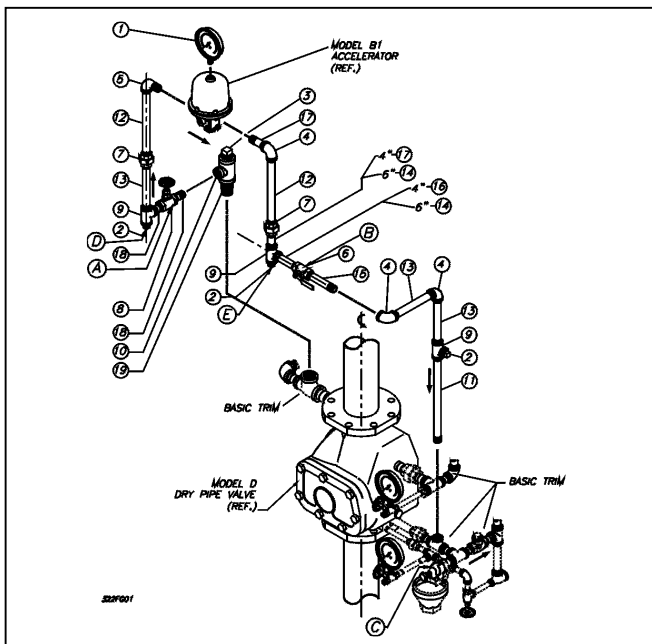

Fig. 1

## Installation

The Reliable Model B1 Accelerator is quickly attached to the Reliable Model D, 4" or 6" Dry Pipe Valve using the Model BD-2 Accelerator Trimmings. No alterations are required to the sprinkler system for this installation. Figure 1 depicts the trimmings and indicates the dry pipe valve attachment points.

For connection to Reliable Models B, C1 or C2 Dry Pipe Valves or other dry pipe valves, the general principles of the Reliable Model BD-2 Accelerator Trimmings should be used. For connection to Model LDX Dry Pipe Valves refer to bulletin 354.

The Model B1 Accelerator may be capable of hastening the operation of other makes of dry pipe valves having intermediate chamber design. However, it has been tested and approved only with Reliable Dry Pipe Valves.

Reliable's Accelerator is UL Listed for system volumes to 1500 gallons. This capability is also approved by FM.

It must be cautioned that accelerator operation and water delivery at the inspectors test connection does not occur at the same time. There is a delay while the air is being expelled through the inspectors test connection ahead of the water. This time delay depends on the piping configuration system size, available water supply and other factors which are beyond the control of the accelerator and restrict the system's capability to deliver water in the 60 second time requirement. While field installation experience will aid in the determination of system size limitations, it is recommended that the Reliable Technical Service Department be consulted when large volume systems are encountered.

## Model BD-2 Accelerator Trimmings for Connecting Model B1 Accelerators to Model D 4" & 6" Dry Pipe Valves

Item No.		Part No.	Description	No. Supl.
Valve Size				
4"	6"			
1	1	98248000	Gauge, Pressure-Air	1
2	2	98604406	Plug, $\frac{1}{2}$ "	3
3	3	98604405	Plug, 1"	1
4	4	98174401	Elbow, $\frac{1}{2}$ "	3
5	5	98174400	Elbow, Street, $\frac{1}{2}$ "	1
6	6	98840105	Ball Valve, $\frac{1}{2}$ "	1
7	7	98815200	Union, $\frac{1}{2}$ "	2
8	8	98840171	Valve, Globe, Bronze $\frac{1}{2}$ "	1
9	9	98761651	Tee, $\frac{1}{2}$ " x $\frac{1}{2}$ " x $\frac{1}{2}$ "	3
10	10	98761650	Tee, 1" x 1" x $\frac{1}{2}$ "	1
11	11	98543252	Nipple, $\frac{1}{2}$ " x 10 $\frac{1}{2}$ "	1
12	12	98543235	Nipple, $\frac{1}{2}$ " x 8 $\frac{1}{2}$ "	2
13	13	98543204	Nipple, $\frac{1}{2}$ " x 6"	3
—	14	98543202	Nipple, $\frac{1}{2}$ " x 5 $\frac{1}{2}$ "	2
—	—	—	—	—
15	15	98543207	Nipple, $\frac{1}{2}$ " x 4"	1
16	—	98543216	Nipple, $\frac{1}{2}$ " x 3 $\frac{1}{2}$ "	1
17	—	98543210	Nipple, $\frac{1}{2}$ " x 2 $\frac{1}{2}$ "	2
—	17	98543210	Nipple, $\frac{1}{2}$ " x 2 $\frac{1}{2}$ "	1
18	18	98543209	Nipple, $\frac{1}{2}$ " x 2"	2
19	19	98543213	Nipple, 1" x Close	1

## Reliable Model B1 Accelerator with Integral Accelo-Check

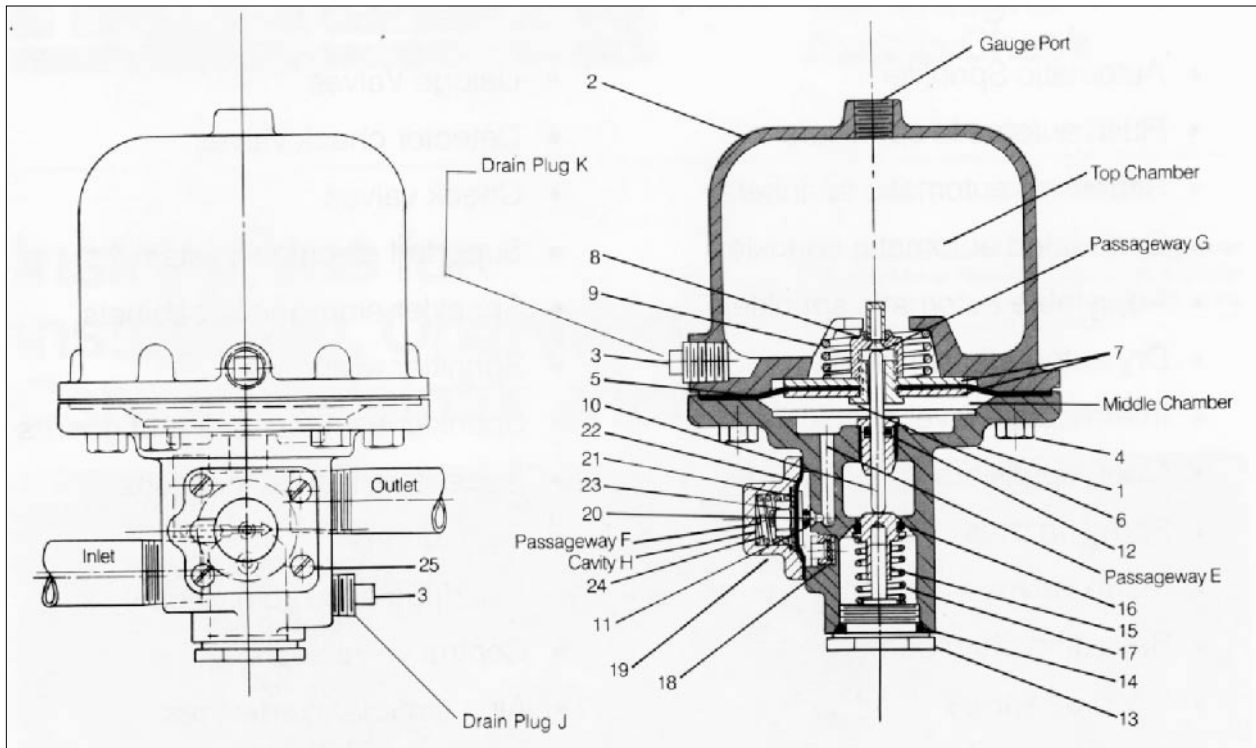

Figure 2

### List of Accelerator Parts

Item No.	Part No.	Description	No. Req.
1	91007000	Body/Push Rod Guide, Sub-Assy	1
2	92106411	Top Chamber Cover	1
3	98604413	Drain Plug 1/4"	2
4	91106311	Top Chamber Bolt	6
5*	92206311	Sensing Diaphragm	1
6	95276321	Diaphragm Retainer	1
7	96906311	Diaphragm Washer	2
8*	92207000	Diaphragm Nut — Filter Sub-Assy	1
9	96406311	Diaphragm Spring	1
10*	95506307	Push-Rod	1
11*	95406311	'O' Ring, Accelo-Check	1
12*	95406315	'O' Ring, Push Rod Guide	1

Should replacement parts be needed, use only Genuine Reliable Made Parts. When ordering, specify part name and number. Also name, size, model and serial number of the unit.

Item No.	Part No.	Description	No. Req.
13	73016333	Valve Plug Assembly	1
14*	95406312	'O' Ring, Valve Plug	1
15	95226321	Poppet	1
16*	95406313	'O' Ring, Poppet	1
17	96406314	Poppet Spring	1
18*	73016343	Filter Assembly	1
19	91006417	Accelo-Check Body	1
20	95226327	Accelo-Check Poppet	1
21	96906327	Accelo-Check Washer	1
22*	92206317	Accelo-Check Diaphragm	1
23	94906327	Accelo-Check Nut	1
24	96406317	Accelo-Check Spring	1
25	95606311	Accelo-Check Screw	4

\*These items are contained in Replacement Parts Kit, Part No. 6888000100.

### System Requirements

NFPA 13 titled "Installation of Sprinkler Systems", specifies that accelerators (quick-opening devices) are required in dry systems having capacities of more than 500 gallons. However, exceptions permit the omission

of quick-opening devices for larger systems when water can be delivered to the inspector's test connection in less than 60 seconds.

## Maintenance

The following table provides a simplified, trouble shooting guide which indicates the necessary corrective

maintenance for the more common problems which may occur.

Symptom	Probable Cause	Correction
Air Flows rapidly through Accelerator into outlet when resetting (air pressure at ball drip valve).	<ol style="list-style-type: none"> <li>1. Vacuum in middle chamber not allowing Accelerator to reset.</li> <li>2. Pushrod held in down position by contamination, pushrod bent or pushrod guide too tight.</li> </ol>	<ol style="list-style-type: none"> <li>1. Vent middle chamber per Item 7 in Resetting Procedure Section.</li> <li>2. Clean or replace as needed.</li> </ol>
Minor air flow or leakage through Accelerator.	<ol style="list-style-type: none"> <li>1. Contamination in poppet area.</li> <li>2. Poppet "O" ring has blown off poppet, or is cut.</li> <li>3. Accelo-Check diaphragm has hole or rip allowing air to reach outlet through passageway F.</li> <li>4. Leakage past pushrod guide "O" ring.</li> <li>5. Pushrod or pushrod guide damaged causing leakage.</li> </ol>	<ol style="list-style-type: none"> <li>1. Clean.</li> <li>2. Install new "O" ring.</li> <li>3. Replace.</li> <li>4. Replace.</li> <li>5. Replace.</li> </ol>
No or low air pressure top chamber (Gauge pressure does not increase, and no air pressure in outlet).	<ol style="list-style-type: none"> <li>1. Filter assembly clogged.</li> <li>2. Restriction area (passageway G) clogged or filter on diaphragm nut clogged.</li> </ol>	<ol style="list-style-type: none"> <li>1. Replace.</li> <li>2. Replace.</li> </ol>
Accelerator will not trip during system test.	<ol style="list-style-type: none"> <li>1. Top chamber air pressure bleeding back to system too fast through restriction area.</li> <li>2. Top chamber air pressure bleeding back to system through ripped diaphragm.</li> <li>3. External leak in top chamber.</li> <li>4. Filter assembly restricted.</li> </ol>	<ol style="list-style-type: none"> <li>1. Clean top of Push-Rod and mating surface in diaphragm nut or replace.</li> <li>2. Replace.</li> <li>3. Check gauge and drain plug for tightness-use new *Teflon® tape on plug after each resetting.</li> <li>4. Replace.</li> </ol>
Accelerator floods with water.	<ol style="list-style-type: none"> <li>1. Verify that the valve in accelerator outlet line is not closed preventing dry pipe intermediate chamber pressure from maintaining the Accelo-Check diaphragm in a closed position.</li> <li>2. Accelo-Check "O" ring missing or cut.</li> <li>3. Leakage past pushrod guide "O" ring.</li> <li>4. Pushrod or pushrod guide damaged causing leakage.</li> <li>5. Accelerator trim lines contain water.</li> <li>6. Prime water level too high.</li> </ol>	<ol style="list-style-type: none"> <li>1. Replace with trimmings as specified.</li> <li>2. Replace.</li> <li>3. Replace.</li> <li>4. Replace.</li> <li>5. Drain and purge per resetting procedure.</li> <li>6. Adjust. Relocate the accelerator's inlet system connection to the riser at least 2 ft. above the dry pipe valve.</li> </ol>
Accelerator operates prematurely.	<ol style="list-style-type: none"> <li>1. Water or dirt in restriction area.</li> <li>2. Air not bleeding back through restriction area to compensate for minor pressure fluctuations.</li> <li>3. Dry pipe valve operating prematurely – not accelerator.</li> <li>4. On-Off setting of compressor pressure switch allowing system pressure to decay too far.</li> <li>5. Excessive system leakage.</li> </ol>	<ol style="list-style-type: none"> <li>1. Clean top of pushrod and mating surface-perform sensitivity test.</li> <li>2. Replace pushrod and diaphragm nut – perform sensitivity test.</li> <li>3. Review dry pipe valve bulletin and pressure settings.</li> <li>4. Readjust differential of pressure switch to minimum (6-8 psi) when using accelerator.</li> <li>5. Repair.</li> </ol>

\* DuPont Registered Mark

## Resetting Procedure

1. Close Valves A and B, Fig. 1.
2. Close air and water supply valves to the dry pipe valve. Drain and reset the dry pipe valve in accordance with the valve's installation bulletin.
3. Reclose the main water supply control valve and reopen the dry pipe valve's drain valve.
4. Remove Plugs D and E, Fig. 1.
5. Remove the Body Drain Plug J, Fig. 2.
6. Remove the Top Chamber Drain Plug K. If water is present in the top chamber, disassemble the accelerator, and clean and dry the top and middle chambers and diaphragm assembly using a clean lint free cloth. Reassemble the accelerator. Replace the top chamber drain plug using new thread sealant.
7. Remove the Accelo-Check Body (19), and gently lift the Accelo-Check Diaphragm Assembly (22) to verify venting of the middle chamber. Carefully reinstall these parts.
8. Partially open Valve A, Fig. 1, gently purging any water which may be in the trim lines. Close Valve A. Replace Plugs D and E. Partially open Valve A and gently purge. Close Valve A and replace the Body Drain Plug J, Fig. 2.
9. Pressurize the accelerator by opening Valve A, Fig. 1. Open Valve B and check for leakage at the Ball Drip Valve C. The top chamber pressure should equal the system pressure.
10. Slightly open the main water supply control valve. Close the main drain valve when water flows, then fully open the main supply valve. The system is now ready for service.

## Caution

The presence of water in the accelerator may cause premature operation. Therefore, it is imperative that after system operation, the accelerator be inspected for any signs of water in the top chamber and that the accelerator trim lines are purged prior to completing the accelerator reset procedure. In addition, after system set-up, the prime water level must not exceed the dry pipe valve's prime level. If water is found in the accelerator, due to excessive prime level or back drainage, the accelerator's inlet system connection must be relocated to the riser at least 2 ft. above the dry pipe valve.

## Test & Inspection

The following inspection should be performed on a weekly basis.

1. Check that the correct system air pressure has been set.
2. Verify that accelerator top chamber pressure and system air pressure are equal.
3. Verify that Valves A and B are fully open.
4. Check that the prime water level is correct.
5. Check for leakage at Ball Drip Valve C.

## Test

The following accelerator tests should be performed semi-annually or whenever the accelerator has been disassembled.

### A. Accelerator test without operating the dry pipe valve.

1. Close Valves A and B, Fig. 1, Remove Plug E.
2. Loosen the Body Drain Plug J, Fig. 2, to decay the pressure at the inlet of the accelerator. This will simulate a system decay as when one or more sprinklers open. The accelerator should operate.
3. Reset the accelerator following the instructions described in the "Resetting Procedure" section items 4 through 9.

### B. Sensitivity Test

1. Close the main water supply control valve.
2. Bleed the system air pressure at a rate of 1 psi per minute by opening the prime level valve located on the dry pipe valve.
3. After ten minutes (the air pressure should have decayed 10 psi) the accelerator should not have tripped.
4. Restore the system air pressure and reopen the main water supply control valve.

## Accelerator Operating Time

Figure 3 provides an approximate graph of actual accelerator operating time versus system size when one sprinkler head opens. The time of operation of the accelerator is relatively unaffected by inlet pressures so the graph applies for all normal dry system pressures from 20 psi to 50 psi (1.7 bar to 3.4 bar). As described in the following section, water delivery time will significantly exceed the accelerator operating time shown in Figure 3.

**Note:** 1 bar=100 kPa

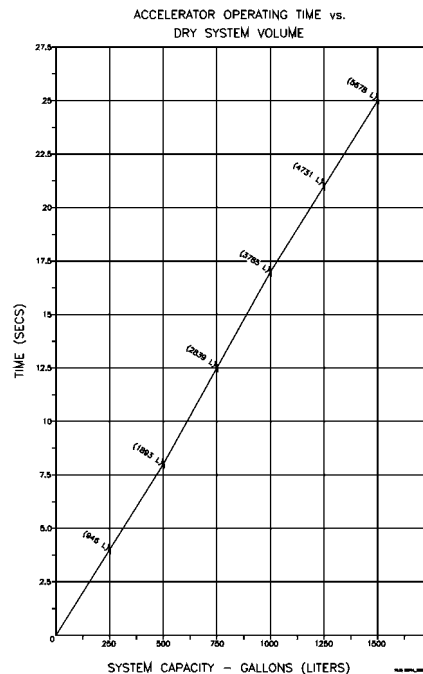

Figure 3

# Reliable...For Complete Protection

Reliable offers a wide selection of sprinkler components. Following are some of the many precision-made Reliable products that guard life and property from fire around the clock.

- Automatic sprinklers
- Flush automatic sprinklers
- Recessed automatic sprinklers
- Concealed automatic sprinklers
- Adjustable automatic sprinklers
- Dry automatic sprinklers
- Intermediate level sprinklers
- Open sprinklers
- Spray nozzles
- Alarm valves
- Retarding chambers
- Dry pipe valves
- Accelerators for dry pipe valves
- Mechanical sprinkler alarms
- Electrical sprinkler alarm switches
- Water flow detectors
- Deluge valves
- Detector check valves
- Check valves
- Supertrol electrical system
- Sprinkler emergency cabinets
- Sprinkler wrenches
- Sprinkler escutcheons and guards
- Inspectors test connections
- Sight drains
- Ball drips and drum drips
- Control valve seals
- Air maintenance devices
- Air compressors
- Pressure gauges
- Identification signs
- Fire department connection

---

The equipment presented in this bulletin is to be installed in accordance with the latest pertinent Standards of the National Fire Protection Association, Factory Mutual Research Corporation, or other similar organizations and also with the provisions of governmental codes or ordinances whenever applicable.

Products manufactured and distributed by Reliable have been protecting life and property for over 80 years, and are installed and serviced by the most highly qualified and reputable sprinkler contractors located throughout the United States, Canada and foreign countries.

---

Manufactured by

**The Reliable Automatic Sprinkler Co., Inc.**

(800) 431-1588      Sales Offices  
(800) 848-6051      Sales Fax  
(914) 668-3470      Corporate Offices  
[www.reliablesprinkler.com](http://www.reliablesprinkler.com)      Internet Address



Revision lines indicate updated or new data  
PG. Printed in U.S.A. 4/03      P/N9999970043