



CAST IRON EQUILIBRIUM BALL FLOAT VALVE

WRAS
APPROVED
PRODUCT

The Peter Smith Valve Company Ltd

FIG: 501



PRESSURE/TEMPERATURE RATING:

50mm-200mm	250mm-300mm	TEMP
10 BAR	7 BAR	Cold
7 BAR	7 BAR	60°C
5 BAR	3 BAR	70°C

FLANGED:

BS 10 Table F

DRILLED:

BS 4504	PN 10
	PN 16
BS 10	Tables D, E, F
ANSI B 16.1	Class 125

APPROVAL:

**WRAS – Water Regulations
Advisory Scheme**

CONSTRUCTION:

1. Bolted cover plate to protect seal and cylinder from the ingress of debris
2. Maintenance simplified by easily replaceable piston seal and steel reinforced renewable rubber disc
3. Adjustable float for optimum water level control
4. The valves are supplied with line flanges to BST F Diam. Unless otherwise instructed the inlet flange will be drilled to match the flange specified on order. The outlet flange will not be drilled unless ordered

MATERIALS:

Body	} Cast Iron to EN 1561 ENGJL250
Cover	
Valve Seat	} Gunmetal to EN 1982 CC491K
Cylinder	
Valve Disc	EPDM Rubber bonded to steel reinforcing plate
Piston Seal	EPDM Rubber
Float	Tough Rilsan nylon coating heat-fused to steel float

FIG: 500

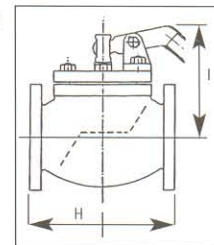

Dimension D Conforms to WRC Requirements for Minimum Height above Water Level Byelaw No.11 Type 'A' Air Gap.

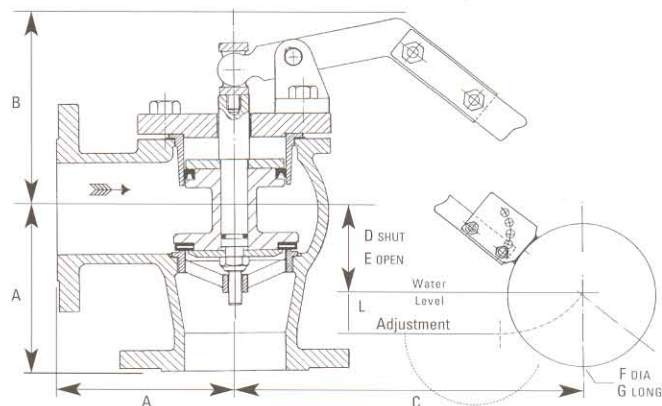

FIG: 501

Dimensions (mm)

Due to HIGH LEVER RATIOS
Dim 'D' is subject to a tol. of +/- 10%

FLOW VELOCITY: It is recommended that flow velocity should not exceed 3m/s (10f/s) giving a maximum flow of: J litres/sec K galls/min

NOMINAL SIZE											FLOW CAPACITY		WEIGHT (Kg)
	A	B	C	D	E	F	G	H	I	J	K	L	
50	125	165	1090	436	700	305	203	203	203	6	78	160	22
80	155	190	1100	560	860	305	292	241	248	14.2	187	160	33
100	178	228	1295	610	1040	356	305	292	267	24.7	326	170	52
150	229	280	1467	760	1284	457	356	356	279	55.7	735	200	96
200	248	305	1714	960	1570	508	356	495	445	98.5	1300	220	143
250	311	381	1950	930	1750	508	356	622	445	175	2300	220	270
300	350	483	2250	1060	2170	508	356	698	483	260	3400	220	311